

## Description

The monkey ladder is an especially important element in an outdoor Fitness Park as it makes dynamic hanging possible which is a basic workout exercise and has various variations with different levels of difficulty. These exercises can be completed on a simple bar as well, however, the monkey ladder provides bigger room for the combination of different training elements making training more enjoyable and diverse. The monkey ladder is available only for ladders as an additional element

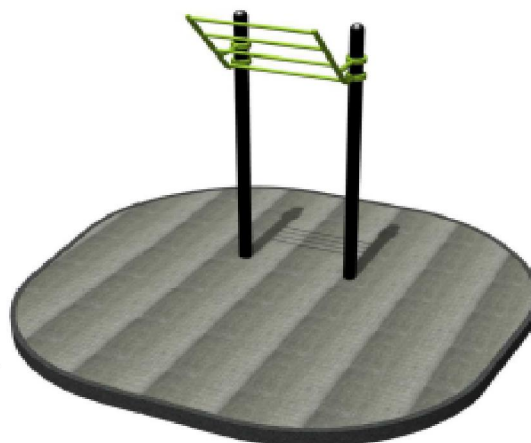

## Plan View

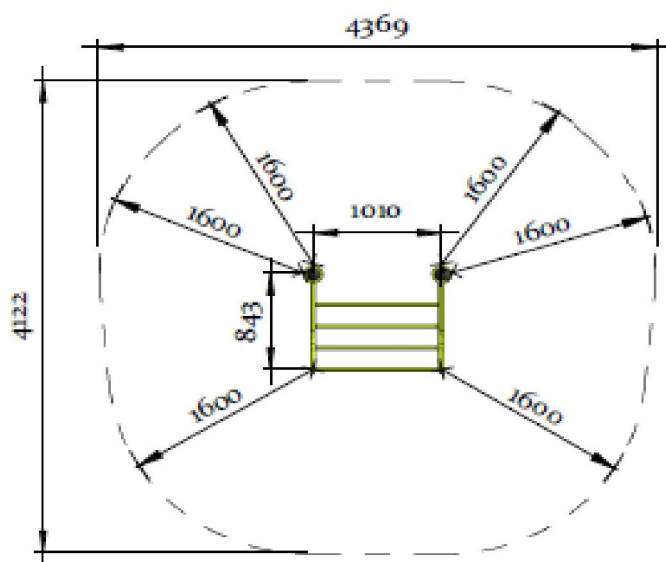

**Producer:**  
 Katker 2005 Kft.  
 4027, Debrecen,  
 Füredi St.49-51

## Side View

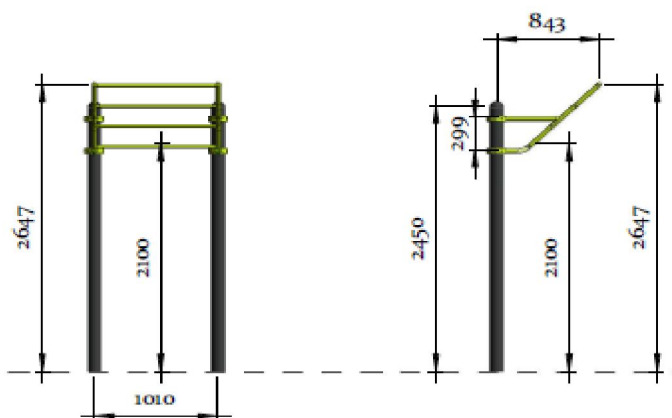

## Technical Datas

Demonination	Monkey ladder
Number	FKP14-H022_B
Certificate	EN 16630
Required floor area	15,37 m2
Column distance	1010 mm
Height (min-max)	2647 mm
Critic falling height (HIC)	1647 mm